

Art. 600 VALVOLE A RITEGNO SERIE ANSI 150
Swing Check valves series ANSI 150

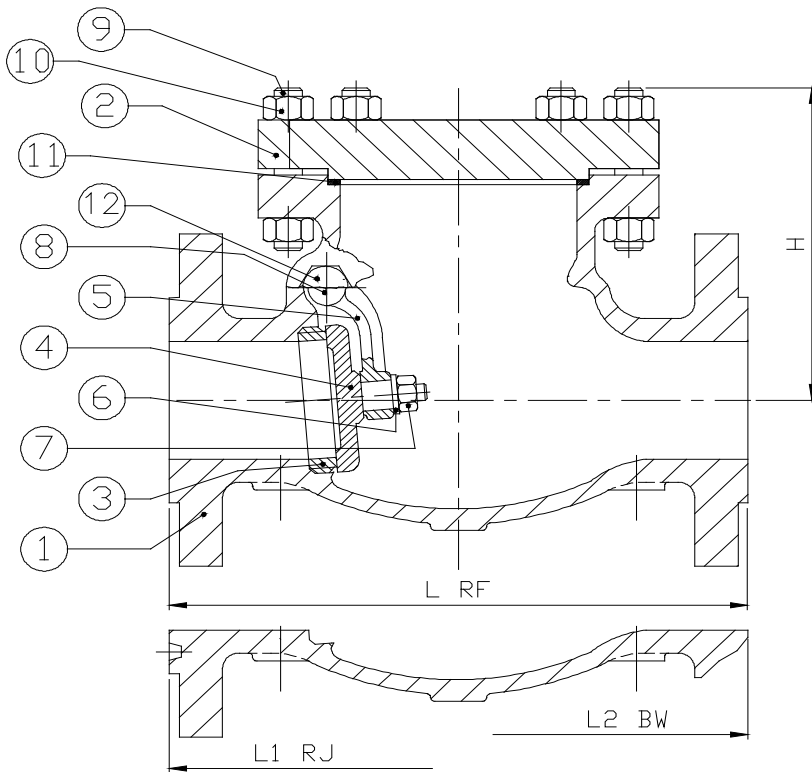

DN	L RF	L1 RJ	L2 BW	H	H1	V
2"	8,00	8 ½	8,00	5 ½		
50	203	216	203	140		
2 ½"	8 ½	9,00	8 ½	6,00		
65	216	229	216	152		
3"	9 ½	10,00	9 ½	7,00		
80	241	254	241	178		
4"	11 ½	12,00	11 ½	8 ½		
100	292	305	292	220		
6"	16,00	14 ½	16,00	11,00		
150	406	368	406	279		
8"	19 ½	20,00	19 ½	13,00		
200	495	508	495	330		
10"	24 ½	25,00	24 ½	15 ½		
250	622	635	622	390		
12"	27 ½	28,00	27 ½	17 ½		
300	698	711	698	440		
14"	31,00	31 ½	31,00	20 ½		
350	787	800	787	520		
16"	34,00	34 ½	34,00	23 ½		
400	864	876	864	600		
18"	38 ½	39,00	38 ½	25,00		
450	978	991	978	635		
20"	38 ½	39,00	38 ½	27 ½		
500	978	991	978	700		
24"	51,00	51 ½	51,00	29 ½		
600	1295	1308	1295	750		
26"	51,00		51,00			
650	1295		1295			
28"	57,00		57,00			
700	1448		1448			
30"	60,00		60,00			
750	1524		1524			
36"	77,00		77,00			
900	1956		1956			
40"	79,00		79,00			
1000	2007		2007			
42"						
1050						
48"						
1200						
64"						
1600						

POS	DENOMINAZIONE - Part list	MATERIALI - Materials
1	CORPO Body	ASTM A216 WCB
2	COPERCHIO Bonnet	ASTM A216 WCB
3	SEDE Seat ring	ASTM A182 F.6
4	OTTURATORE Disc	ASTM A182 F.6
5	LEVA Hinge	ASTM A216 WCB
6	RONDELLA Plate	ASTM A182 F.6
7	DADO Nut	ASTM A194 2H
8	SPINOTTO Pin	ASTM A182 F.6
9	TIRANTI CORPO-COPERCHIO Bolt	ASTM A 193 B7
10	DADI Nut	ASTM A 194 2H
11	GUARNIZIONE Gasket	GRAPHITE+F316
12	TAPPO Plug	ASTM A105
13		
14		
15		
16		
17		
18		
19		
20		
21		
22		
23		
24		
25		
26		