

Art. 550 VALVOLE A GLOBO SERIE ANSI 150
Globe Valves series ANSI 150

(*) Esecuzione su richiesta
Execution by request

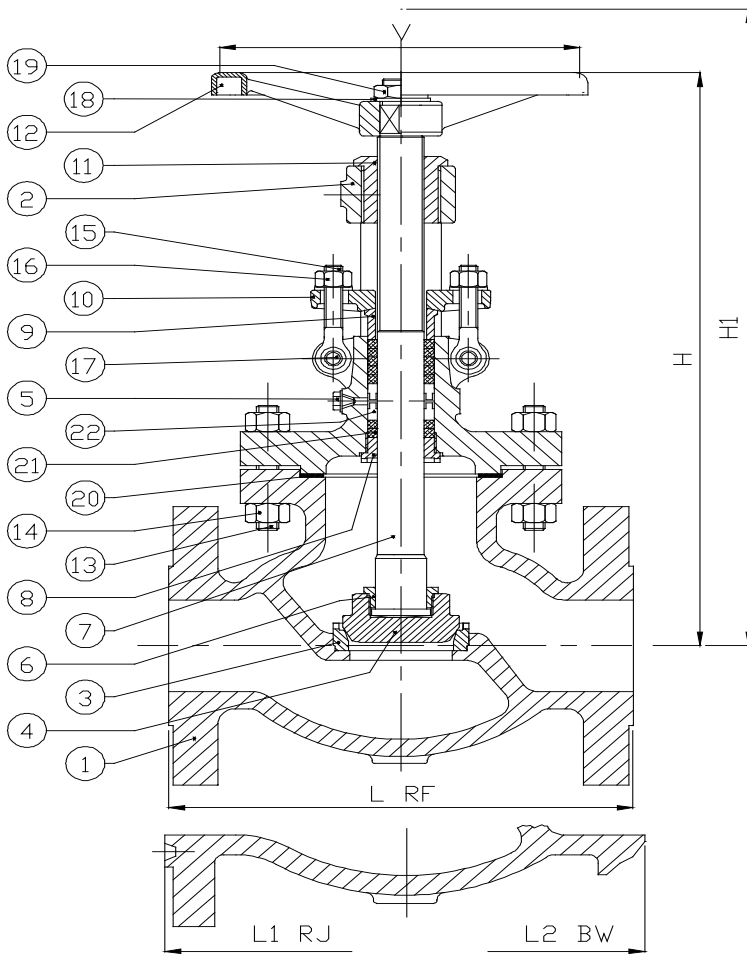

DN	L RF	L1 RJ	L2 BW	H	H1	V
2"	8,00	8 ½	8,00	10,00	11,00	8,0
50	203	216	203	254	280	200
2"½	8 ½	9,00	8 ½	12,00	13 ¾	9,00
65	216	229	216	305	340	225
3"	9 ½	10,00	9 ½	14,00	15 ½	10,00
80	241	254	241	356	396	250
4"	11 ½	12,00	11 ½	16 ½	18 ⅞	10,00
100	292	305	292	410	460	250
6"	16,00	16 ½	16,00	22,00	24 ⅞	14,00
150	406	419	406	559	630	350
8"	19 ½	20,00	19 ½	25 ½	29 ⅞	16,00
200	495	508	495	640	740	400
10"	24 ½	25,00	24 ½	29,00	36 ⅞	
250	622	635	622	737	937	
12"	27 ½	28,00	27 ½	32,00	37 ¾	
300	698	711	698	813	960	
14"	31,00	31 ½	31,00	44,00	51,00	
350	787	800	787	1120	1295	
16"	36,00	36 ½	36,00	49 ⅝	57 ½	
400	914	927	914	1260	1460	
18"	37,00		37,00	42 ¼	61,00	
450	940		940	1150	1550	
20"	38 ½		38 ½	45 ½	65 ¾	
500	978		978	1180	1670	
24"						
600						
26"						
650						
28"						
700						
30"						
750						
36"						
900						
40"						
1000						
42"						
1050						
48"						
1200						
64"						
1600						

WITH GEAR OPERATOR

POS	DENOMINAZIONE - Part list	MATERIALI - Materials
1	CORPO Body	ASTM A216 WCB
2	CAPPELLO Bonnet	ASTM A216 WCB
3	SEDE Seat ring	ASTM A182 F.6
4	OTTURATORE Disc	ASTM A182 F.6
5	TAPPO (*) Plug	ASTM A105
6	GHIERA FERMA STELO Disc nut	ASTM A182 F.6
7	STELO Stem	ASTM A182 F.6
8	CONTROTENUTA Back seat	ASTM A182 F.6
9	PREMISTOPPA Gland	ASTM A182 F.6
10	FLANGETTA Gland flange	ASTM A105
11	BOCCOLA Yoke sleeve	ASTM B148 9A
12	VOLANTINO Handwheel	CARBON STEEL
13	TIRANTI CORPO-CAPPELLO Bolt	ASTM A193 B7
14	DADI Nut	ASTM A194 2H
15	TIRANTI PREMISTOPPA Eye Bolt	ASTM A193 B7
16	DADI Nut	ASTM A194 2H
17	BULLONE Eye bolt/nut	ASTM A193 B7
18	RONDELLA Plate	ASTM A105
19	DADO Nut	ASTM A194 2H
20	GUARNIZIONE Gasket	GRAPHITE+F316
21	GUARNIZIONE Packing	GRAPHITE
22	LANTERNA (*) Lantern ring	ASTM A 182 F.6
23		
24		
25		
26		