

Art. 525 SARACINESCHE SERIE ANSI 2500
Gate valves series ANSI 2500

(*) Esecuzione su richiesta

Execution by request

(**) Solo dalla 3" in su'

Only up 3"

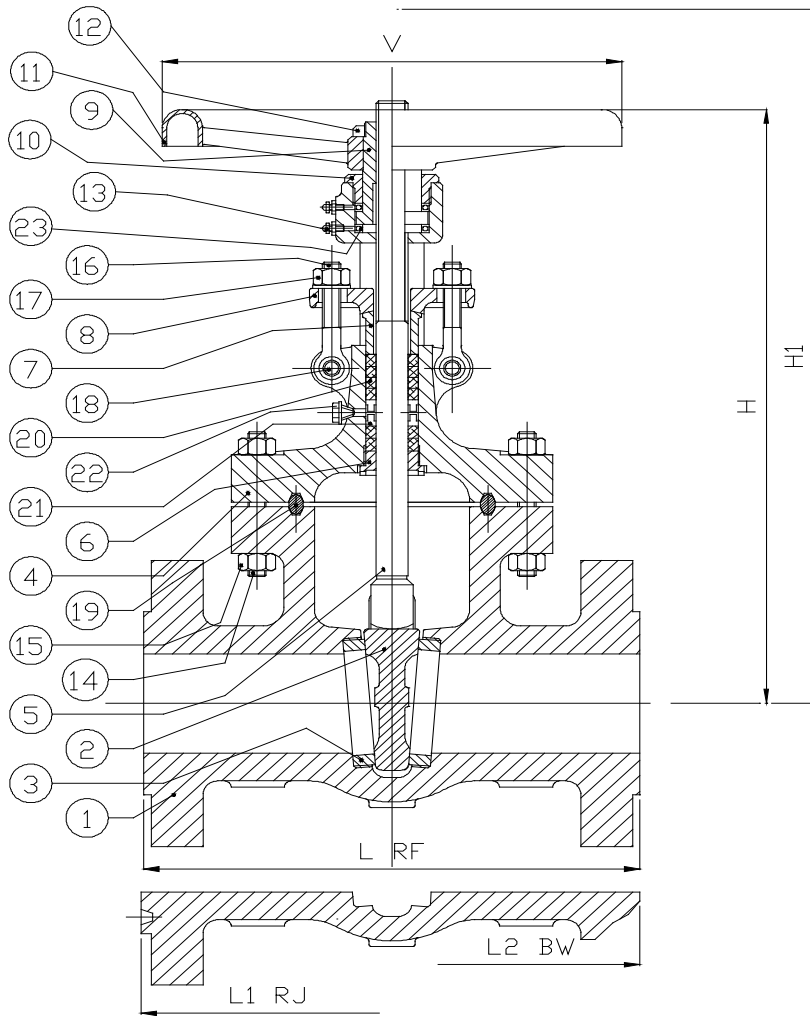

DN	L RF	L1 RJ	L2 BW	H	H1	V
2"	17 3/4	17 7/8	17 3/4	20 1/4	23 3/8	15 3/4
50	451	454	451	515	595	400
2 1/2"	20,00	20 1/4	20,00	23 1/2	27 1/8	15 3/4
65	508	514	508	595	690	400
3"	22 3/4	23,00	22 3/4	24 1/4	28 1/2	19 5/8
80	578	584	578	615	725	500
4"	26 1/2	26 7/8	26 1/2	29 1/8	34 1/4	23 3/8
100	673	683	673	740	870	600
6"	36,00	36 1/2	36,00	38,00	45,00	29 1/2
150	914	927	914	965	1145	750
8"	40 1/4	40 7/8	40 1/4	41 1/8	50 1/8	35 1/2
200	1022	1038	1022	1045	1275	900
10"	50,00	50 7/8	50,00	50 3/8	61 1/2	
250	1270	1292	1270	1280	1560	
12"	56,00	56 7/8	56,00	52 3/8	65 3/8	
300	1422	1444	1422	1330	1660	
14"	AVAILABLE UPON REQUEST					
350						
16"	AVAILABLE UPON REQUEST					
400						
18"	AVAILABLE UPON REQUEST					
450						
20"	AVAILABLE UPON REQUEST					
500						
24"	AVAILABLE UPON REQUEST					
600						
26"						
650						
28"						
700						
30"						
750						
36"						
900						
40"						
1000						
42"						
1050						
48"						
1200						
64"						
1600						

WITH GEAR OPERATOR

POS	DENOMINAZIONE - Part list	MATERIALI - Materials
1	CORPO Body	ASTM A216 WCB
2	CUNEO Wedge	ASTM A182 F.6
3	SEDE Seat ring	ASTM A182 F.6
4	CAPPELLO Bonnet	ASTM A216 WCB
5	STELO Stem	ASTM A182 F.6
6	CONTROTENUTA Back seat	ASTM A182 F.6
7	PREMISTOPPA Gland	ASTM A182 F.6
8	FLANGETTA Gland flange	ASTM A105
9	MADREVITE Yoke sleeve	ASTM B148 9A
10	GHIERA FERMA MADREVITE Yoke nut	ASTM A105
11	VOLANTINO Handwheel	CARBON STEEL
12	GHIERA FERMA VOLANTINO Handwheel nut	ASTM A105
13	INGRASSATORE Grease fitting	CARBON STEEL
14	TIRANTI CORPO-CAPPELLO Bolt	ASTM A193 B7
15	DADI Nut	ASTM A194 2H
16	TIRANTI PREMISTOPPA Eye Bolt	ASTM A193 B7
17	DADI Nut	ASTM A194 2H
18	BULLONE Eye bolt/nut	ASTM A193 B7
19	GUARNIZIONE Gasket	ARMCO
20	GUARNIZIONE Packing	GRAPHITE
21	LANTERNA (*) Lantern ring	ASTM A182 F.6
22	TAPPO (*) Plug	ASTM A105
23	CUSCINETTI (**) Bearing	CARBON STEEL
24		
25		
26		