

Art. 520 SARACINESCHE SERIE ANSI 1500
Gate valves series ANSI 1500

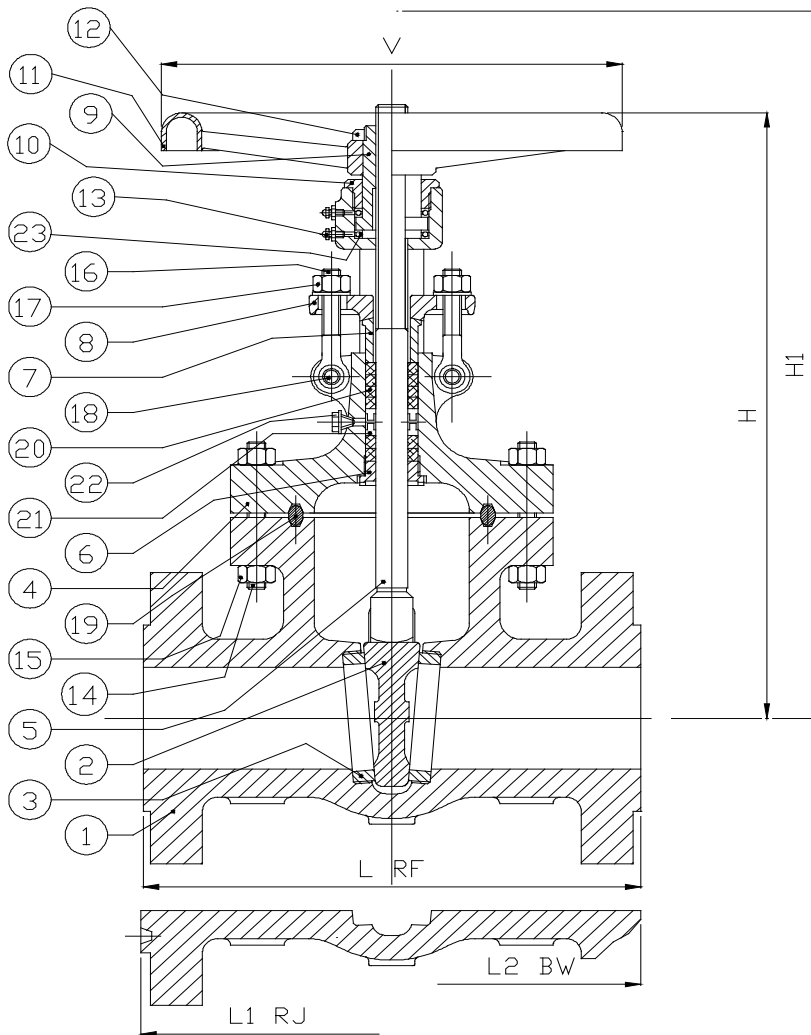

(*) Esecuzione su richiesta
Execution by request

(**) Solo dalla 3" in su'
Only up 3"

DN	L RF	L1 RJ	L2 BW	H	H1	V
2"	14 ½	14 ⅝	14 ½	20,00	22 ⅜	16,00
50	368	371	368	510	570	400
2"½	16 ½	16 ⅝	16 ½	22 ⅜	26 ¾	16,00
65	419	422	419	570	680	400
3"	18 ½	18 ⅝	18 ½	22 ⅜	26 ¾	20,00
80	470	473	470	570	680	500
4"	21 ½	21 ⅝	21 ½	23 ⅝	28 ¾	24,00
100	546	549	546	600	730	600
6"	27 ¾	28,00	27 ¾	39,00	46,00	26,00
150	705	711	705	990	1170	650
8"	32 ¾	33 ⅝	32 ¾	45 ½	54 ½	29 ½
200	832	841	832	1155	1385	750
10"	39,00	39 ⅝	39,00	48 ⅝	59 ⅝	35 ½
250	991	1000	991	1235	1515	900
12"	44 ½	45 ⅝	44 ½	58 ⅞	71 ⅞	
300	1130	1146	1130	1495	1825	
14"	49 ½	50 ¼	49 ½	63,00	78 ⅞	
350	1257	1276	1257	1600	1985	
16"	54 ½	55 ⅝	54 ½	66,00	82 ⅞	
400	1384	1406	1384	1675	2105	
18"	60 ½	61 ⅝	60 ½	71 ⅞	90 ¾	
450	1537	1559	1537	1825	2305	
20"	65 ½	66 ⅝	65 ½	81,00	101¾	
500	1664	1686	1664	2055	2585	
24"	76 ½	77 ⅝	76 ½	87½	112½	
600	1943	1971	1943	2225	2855	
26"						
650						
28"						
700						
30"						
750						
36"						
900						
40"						
1000						
42"						
1050						
48"						
1200						
64"						
1600						

WITH GEAR OPERATOR

POS	DENOMINAZIONE - Part list	MATERIALI - Materials
1	CORPO Body	ASTM A216 WCB
2	CUNEO Wedge	ASTM A182 F.6
3	SEDE Seat ring	ASTM A182 F.6
4	CAPPELLO Bonnet	ASTM A216 WCB
5	STELO Stem	ASTM A182 F.6
6	CONTROTENUTA Back seat	ASTM A182 F.6
7	PREMISTOPPA Gland	ASTM A182 F.6
8	FLANGETTA Gland flange	ASTM A105
9	MADREVITE Yoke sleeve	ASTM B148 9A
10	GHIERA FERMA MADREVITE Yoke nut	ASTM A105
11	VOLANTINO Handwheel	CARBON STEEL
12	GHIERA FERMA VOLANTINO Handwheel nut	ASTM A105
13	INGRASSATORE Grease fitting	CARBON STEEL
14	TIRANTI CORPO-CAPPELLO Bolt	ASTM A193 B7
15	DADI Nut	ASTM A194 2H
16	TIRANTI PREMISTOPPA Eye Bolt	ASTM A193 B7
17	DADI Nut	ASTM A194 2H
18	BULLONE Eye bolt/nut	ASTM A193 B7
19	GUARNIZIONE Gasket	ARMCO
20	GUARNIZIONE Packing	GRAPHITE
21	LANTERNA (*) Lantern ring	ASTM A182 F.6
22	TAPPO (*) Plug	ASTM A105
23	CUSCINETTO (**) Bearing	CARBON STEEL
24		
25		
26		