

Art. 1110 VALVOLE A GLOBO SERIE ANSI 600 CRIOGENICHE
Globe valves series ANSI 600 for cryogenic service

(*) Esecuzione su richiesta
 Execution by request

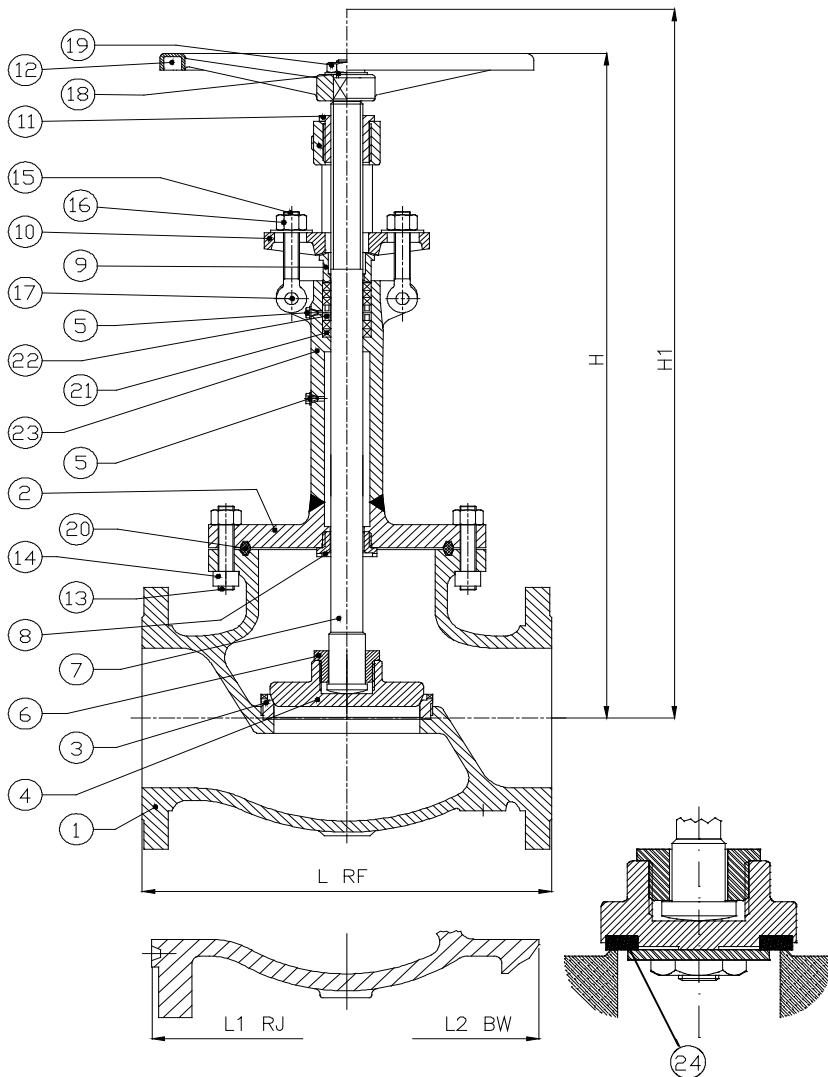

DN	L RF	L1 RJ	L2 BW	H	H1	V
2"	11 ½	11 ⅝	11 ½	40 ½	41 ½	10,00
50	292	295	292	1030	1055	250
2"½	13,00	13 ⅞	13,00	42 ⅓	43 ½	10,00
65	330	333	330	1075	1105	250
3"	14,00	14 ⅞	14,00	43 ½	45,00	12,00
80	356	359	356	1105	1145	300
4"	17,00	17 ⅞	17,00	52 ½	54 ½	14,00
100	432	435	432	1335	1385	350
6"	22,00	22 ⅞	22,00	58 ⅞	61 ½	20,00
150	559	562	559	1495	1565	500
8"	26,00	26 ⅞	26,00	60 ⅝	64 ½	32,00
200	660	664	660	1540	1640	800
10"	31,00	31 ⅞	31,00	73 ⅞	78 ½	36,00
250	787	791	787	1875	1995	900
12"	33,00	33 ⅞	33,00	80 ¾	86 ½	40,00
300	838	841	838	2050	2200	1000

14"						
350						
16"						
400						
18"						
450						
20"						
500						
24"						
600						
26"						
650						
28"						
700						
30"						
750						
36"						
900						
40"						
1000						
42"						
1050						
48"						
1200						
64"						
1600						

POS	DENOMINAZIONE - Part list	MATERIALI - Materials
1	CORPO Body	ASTM A351 CF8M
2	CAPPELLO Bonnet	ASTM A351 CF8M
3	SEDE Seat ring	AISI 316
4	OTTURATORE Disc	AISI 316
5	TAPPO Plug	AISI 316
6	GHIERA FERMA STELO Disc nut	AISI 316
7	STELO Stem	AISI 316
8	CONTROTENUTA Back seat	AISI 316
9	PREMISTOPPA Gland	AISI 316
10	FLANGETTA Gland flange	AISI 316
11	BOCCOLA Yoke sleeve	ASTM B148 9A
12	VOLANTINO Handwheel	CARBON STEEL
13	TIRANTI CORPO-CAPPELLO Bolt	ASTM A193 B8
14	DADI Nut	ASTM A194 GR.8
15	TIRANTI PREMISTOPPA Eye Bolt	ASTM A193 B8
16	DADI Nut	ASTM A194 GR.8
17	BULLONE Eye bolt/nut	ASTM A194 GR.8
18	RONDELLA Plate	AISI316
19	DADO Nut	ASTM A194 GR.8
20	GUARNIZIONE Gasket	METAL
21	GUARNIZIONE Packing	GRAPHITE
22	LANTERNA (*) Lantern ring	AISI 316
23	PROLUNGA Extension	AISI 316
24	TENUTA MORBIDA (*) Soft Seat	PTFE
25		