



SERIES 900

PN 6/10/16 // Class 150
DN 32–1600 (NPS 1¼–64)
Industrial applications
Water, chemicals
Oil & gas, air



RESILIENT SEATED BUTTERFLY VALVES

WWW.ABOVALVE.COM

GENERAL INFORMATION

INTRODUCTION TO SERIES 900

ABO Series 900 are premium quality, resilient seated butterfly valves designed for use in industrial applications. Whether it is potable, sewage, sea or industrial water, light chemicals, pharmaceuticals, oil or oil derivatives, sugar juice, as well as applications in the food processing industry, ABO Series 900 will provide you with long-term reliability and low maintenance requirements, all this at an affordable cost. Series 900 butterfly valves have a groove and tongue design, with double sided profiles of the liner ensuring proper alignment of the sleeve in the outer body, and a forming lobe for securing liner stability. The valve design encompasses a three stage sealing system that yields perfect tightness. Thanks to its extended neck, the ABO Series 900 butterfly valve provides for full thermal isolation of the actuator from the media thermal impact. Further, upward movement of the stem is avoided by a security grub screw in the body neck (blow-out proof). Thanks to a 2-piece stem system, and a highly profiled disc, the ABO Series 900 achieve high Cv (Kv) values and lower pressure drops. This simple but important feature ensure that ABO Series 900 butterfly valves are much more environmentally friendly compared to regular types of butterfly valves, as they consume less energy while being operated in the system.

GENERAL CHARACTERISTICS

- Concentric design
- Shut-off and regulating device
- Splitted shaft
- Pivot fixed by screw allows disassembly (demountable version)
- Long neck of the body according to heating system requirements
- Orange epoxy painting RAL 2002 – minimal thickness of 80 µm
- Suitable for vacuum service of 0,2 bar abs (with bonded liner)
- Safe movement of disc ensured by squared stem/disc connection
- ATEX certificate (Group II, Category 1/2 GD TX)
- Approved for gas and drinking water applications by DVGW, certification

APPLICATIONS

Butterfly valves series 900 are suited for many applications where tight shut-off is required, such as:

- Industrial processing
- Water and wastewater
- Dry bulk conveying
- Light slurry handling
- Paper mills
- Food and beverage
- HVAC (heating, ventilating & air conditions)
- Non-mining environments and explosive atmosphere consisting of dust and gas (zones 0, 1, 20, 21)

STANDARDS

LEAK TEST:

- EN 12266-1, Rate A
- ISO 5208, Rate A
- API 598, Table 5
- ANSI/FCI 70-2, Class VI

FACE TO FACE:

- EN 558, Series 20/13
- ISO 5752, Series 20/13
- API 609, Table 2

TOP FLANGE:

- ISO 5211

CONNECTION

BETWEEN FLANGES:

- EN 1092-1+A1, 2
- ASME B16.5
- ASME B16.47

WORKING STANDARD:

- EN 593
- EN 1074-1,2
- DVGW W 363-(P)
- DIN EN 13774

TYPE DESIGNATION

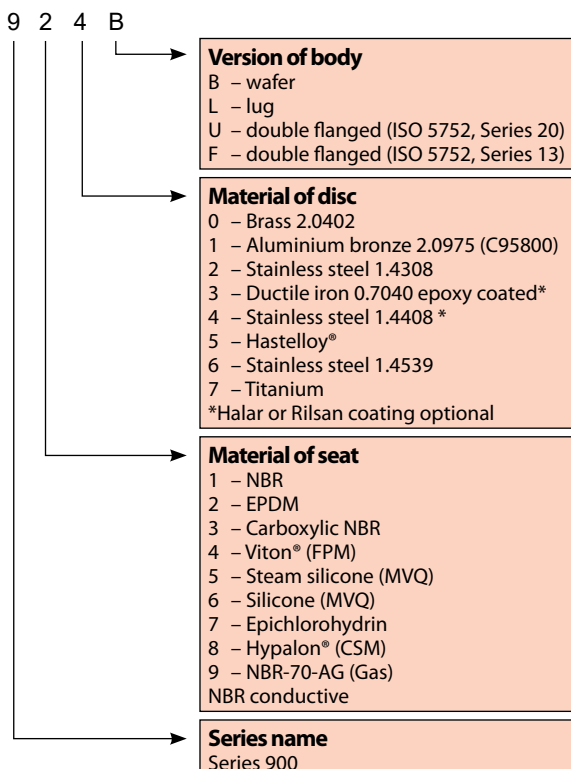

MODELS

Wafer type B

Lug type T

Double flanged type U
(EN 558, Series 20)
for DN 700 – DN 1600

Double flanged type F
(EN 558, Series 13)



PRODUCT QUALITY AND CONTROL

- ABO production facilities are certified in accordance to ISO 9001 (ISO 14000, OHSAS 18000) quality system
- Test procedures are established according to EN 12266-1, ISO 5208, API 598, ANSI/FCI 70-2
- Manufactured according to the requirements of the European Directive 2014/68/EU (PED) and applicable international standards
- All ABO valves pass pressure tests to 110% of rated pressure to ensure bubble tight shutoff
- All actuators are calibrated and cycle tested before shipment
- Material Traceability Rule – Certification is provided for all supplied valves upon customer's request
- Positive Material Identification – All materials are subjected to PMI testing in order to verify Material Traceability Certificate
- Certificates – Complete list of certificates and approvals can be found on <http://www.abovalve.com>

DESIGN BENEFITS

INTERNATIONAL STANDARD COMPATIBILITY

Top flange according to standard ISO 5211 enables direct mounting of manual operators and actuators. Longer neck of ABO butterfly valves result in insulation of ISO top flange (protection of mounted actuator) and meeting heating system requirements.

BLOW-OUT PROOF SHAFT SYSTEM

Upward movement of the shaft is avoided by safety retainer in the body neck.

2-PIECED SHAFT SYSTEM

The divided shaft-pivot system with a highly profiled disc ensure high Kv (Cv) values and lower pressure drops.

SEAT DESIGN

The seat is anchored in the body (groove and tongue design), thus preventing its movement against the body.

DOUBLE-SIDED PROFILES

Double-sided profiles ensure proper alignment of the sleeve in the outer body recess.

DEMOUNTABLE VALVE DESIGN

ABO Series 900 design allows for valve disassembly and easy liner replacement.

FORMING LOBE

Liner stability is secured by a forming lobe, which fits perfectly into the relevant groove of the body.

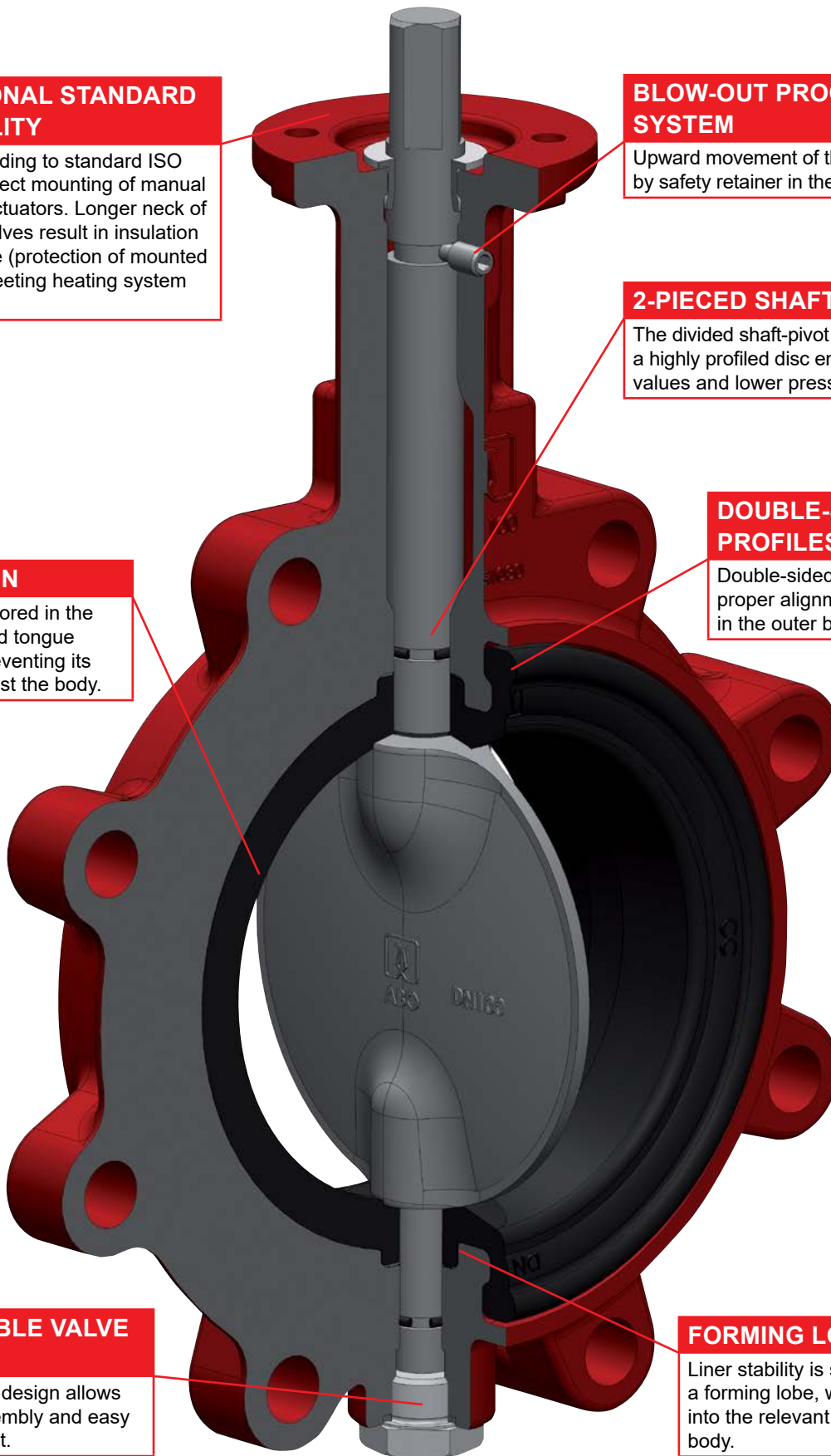

DESIGN BENEFITS

3-STAGE SEALING SYSTEM

A triple safety feature system of sealing security designed by ABO engineers provides for a 100% tight shut-off, long term product life, and a safe mode of operation in the most demanding applications.

PRIMARY SEALING

Sealing surface of the seat in the contact area with both the stem and the pivot respectively, has a precisely defined spherical geometry, which exactly replicates the geometry of the disc.

SECONDARY SEALING

The secondary sealing feature is being created by the stem (pivot) overlap in the relation of the seat bore diameter.

TERTIARY SEALING

ABO Series 900 butterfly valves are equipped with safety O-rings that further enhance operational performance and reliability.

SPOTLIGHT: OPTIONS OF SEAT ANCHORING

GROOVE AND TONGUE VERSION

The classical premium design of groove and tongue anchoring prevents movement of the seat, yet at the time allows for material interchangeability and easy seat replacement.

VULCANIZED SEAT VERSION

A vulcanized seat option is available for high vacuum applications or for negative pressure conditions. For lower vacuum applications (below 0,2 bar abs), a glued-seat version option is also available.

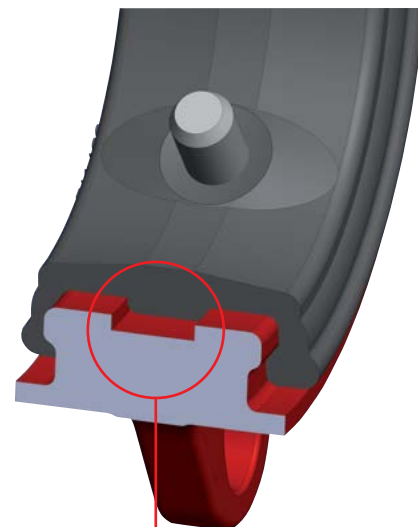

Example of groove and tongue liner anchoring whereby the forming lobe prevents liner from movement.

EXTERNAL COATING OPTIONS

HIGH QUALITY EPOXY COATING

ABO standard coating is premium quality epoxy grade C2 with minimal thickness of 80 µm.

MARINE COATING

Marine coating for highly corrosive atmosphere especially in marine environment is an option. ISO 12944 grades C3, C4 and C5 are available.

RILSAN 11 COATING

Rilsan 11 coating provides superb corrosion resistance. This coating option is recommended for applications such a seawater, cement, food or water service contaminated with chemicals.

AMERLOCK COATING

Amerlock operator coating provides superior protection in sea water environment.

SPECIAL PURPOSE VALVES

ALUMINIUM BODY VALVES FOR SWIMMING POOLS

ABO series 900 butterfly valves with aluminium body are, due to lower weight, ideal for usage in applications where plastic piping is required. This valve design is especially suitable for swimming pool water applications.

- DN 50–200
- Maximum working pressure: 3 bar
- Temperature range: -10 °C to +100 °C

ALUMINIUM BRONZE BODY VALVES FOR MARINE SERVICE

ABO offers high quality resilient-seated butterfly valves fully from aluminium bronze material to meet the requirements of today's industrial/marine markets. These valves are specifically designed for onshore and offshore service where maximum product reliance is required in an extremely corrosive environment with high levels of salinity.

MATERIALS & TECHNICAL INFORMATION

EPDM WITH DVGW CERTIFICATION FOR DRINKING WATER

ABO Series 900 resilient seated butterfly valves are certified by the German Institute DVGW CERT GmbH for potable water service (DVGW W 363-(P)). Valves with this certification are available in sizes DN 32-600 and represent a reliable solution for diverse applications for drinking water as well as for the waste water industry.

EPDM WITH FDA APPROVAL FOR FOOD INDUSTRY

ABO Series 900 FDA approved black EPDM liner can be used for applications in the food industry from -10 °C to +130 °C. Typical applications for this series are sugar mills, beverage and malt factories.

NBR WITH DVGW CERTIFICATION FOR GAS SERVICE

A special NBR seat certified by the German Institute DVGW CERT GmbH is available for gas and biogas applications (DIN EN 13774).

VITON® BIO LINER FOR BIODIESEL

Viton® Bio is a liner with high fluorine content (70%). It provides for excellent chemical resistance and is suitable for media such as acids, oils or biodiesel with temperatures ranging from -5 °C to +150 °C.

LINERS FOR HIGHLY ABRASIVE MEDIA

Subject to proper material seat selection, ABO series 900 butterfly valves can be used for service in severely abrasive environment:

a) Carboxylic NBR (Nitrile rubber) – this basic material variation is suitable for use in an oily environment where abrasive particles are present.

b) Flucast® – ABO Series 900 butterfly valves equipped with Flucast® liners, are the ideal solution for dry bulk conveying, handling of slurries, dust products (gypsum, carbon black, kaolin, oxides), and pneumatic conveying of cement and powder in the mining industry. Depending on the blend, ABO series 900 Flucast® liners can be also used in the food industry (FDA approved), as well as in the oil industry for media such as crude oil.



WORKING CONDITIONS

Maximum working pressure

- DN 32–600: 16 bar*
- DN 700–1 600: 10 bar (16 bar upon request)*

Temperature range:

- max. -30 °C to +150 °C, depending on material selection

* If the working temperature is higher than +120 °C, maximum working pressure changes from 16 bar to 14,4 bar, and from 10 bar to 9 bar.



Series 900 – Potable water application



Series 900 – Biogas application

MATERIALS & TECHNICAL INFORMATION

DRAWING & MATERIALS

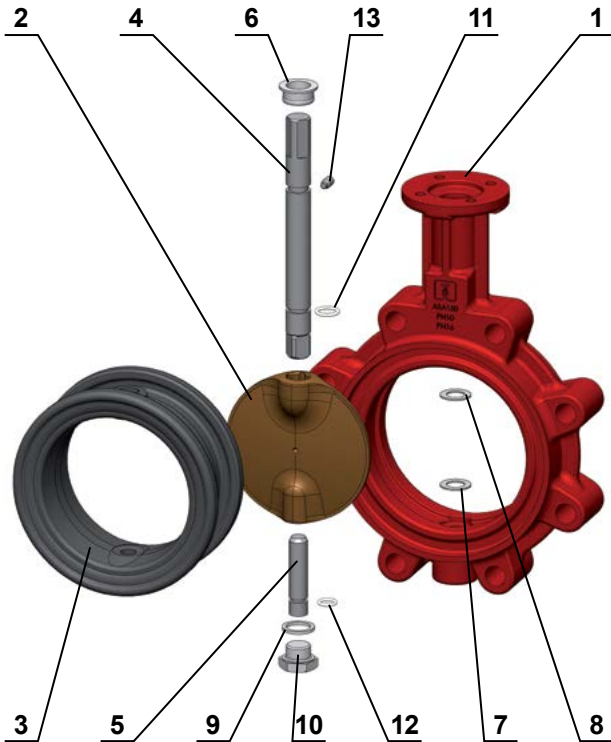

Item	Name	Material
1	Body	Ductile iron 0.7040 (EN-GJS-400-15) epoxy coated Carbon steel 1.0625 (WCB) Low temperature carbon steel 1.1156 (LCC) Stainless steel 1.4408 (CF8M) Aluminium EN AC 43000 (C95500) Aluminium bronze 2.0975 (C95800)
2	Disc	0 – Brass 2.0402 (UNS C38000) 1 – Aluminium bronze 2.0975 (C95800) 2 – Stainless steel 1.4308 (CF8) 3 – Ductile iron 0.7040 (EN-GJS-400-15) epoxy coated* 4 – Stainless steel 1.4408 (CF8M)* 5 – Hastelloy® 6 – Stainless steel 1.4539 (NO8904) 7 – Titanium
3	Seat	1 – NBR -10°C to 100°C 2 – EPDM -25°C to 125°C 3 – Carboxylic NBR -10°C to 100°C 4 – Viton® (FKM) -15°C to 150°C 5 – Steam silicone (MVQ) -30°C to 140°C 6 – Silicone (MVQ) -30°C to 150°C 7 – Epichlorohydrin -30°C to 70°C 8 – Hypalon® (CSM) -25°C to 120°C 9 – NBR 70-AG -10°C to 60°C NBR conductive -10°C to 80°C
4	Shaft	Stainless steel 1.4021 (AISI 420)
5	Pivot	Stainless steel 1.4021 (AISI 420)
6	Bushing	Delrin (up to DN 300) Brass (from DN 350)
7	Distance ring	Stainless steel 1.4301 (AISI 304, A2)
8	Distance ring	Stainless steel 1.4301 (AISI 304, A2)
9	Seal	Klingsil C-4400/ Copper
10	Plug screw	Stainless steel 1.4401 (AISI 316)
11	Shaft O-ring	NBR, EPDM, Viton® is an option
12	Pivot O-ring	NBR, EPDM, Viton® is an option
13	Retaining screw	Stainless steel 1.4301 (AISI 304, A2)

Execution in other material types can be provided upon request. Choice of the seat and disc materials for various media will be recommended upon specific enquiry. Max. temperatures for each material of seat are accepted only for a specific medium and short time exposure.

Max. temperature for water services only up to 80°C.
*Available with optional Rilsan or Halar coating.

INSTALLATION BETWEEN FLANGES (DN 32–600)

Vers.	Flange / DN	32/40	50	65	80	100	125	150	200	250	300	350	400	450	500	600
B	PN6											•	•	•	•	•
	PN10															
	PN16													•		
	Class 150											•	•	•		
T	PN6	•	•	•	•	•	•	•	•	•	•	•	•	X	X	X
	PN10													•	•	•
	PN16								•	•	•	•	•	•	•	•
	Class 150	•	•	•	•	•	•	•	•	•	•	•	•	•	•	•
F	PN10	X														
	PN16	X														

*For other connections, please consult with manufacturer.

INSTALLATION BETWEEN FLANGES (DN 700–1600)

Vers.	Flange / DN	700	800	900	1000	1200	1400	1600
U	PN6	•	•	•	•	•	•	•
	PN10							
	PN16	•	•	•	•	•	•	•
	Class 150	•	•	•	•	•	•	•

* For JIS 5K/10K, please consult with ABO.

□ standard □ • upon request □ X not suitable



Water treatment plant in Vienna, Austria

ACTUATION & TORQUES

ACTUATION POSSIBILITIES

All ABO handles, manual gear operators, pneumatic and electric actuators can be mounted directly to ABO butterfly valves, thus eliminating brackets or couplings. This allows for simple installation in the field, minimizes possible misalignment and decrease overall height.

MANUAL ACTUATION: HANDLEVER

For manual actuation, ABO offers levers in carbon steel material with protective coating for excellent corrosion, abrasion and impact resistance. A lever in stainless steel material is an option. ISO top flange connection is F05 for DN 50 and 65 (NPS 2 and 2½), and F07 for DN 80 – 200 (NPS 3 – 8), respectively. Hand lever in regulating design optional.

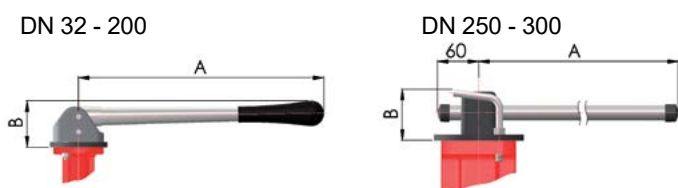

DN	32-100	125	150-200	250	300
NPS	1¼-4	5	6-8	10	12
A	270		362	450	750
B	75	75	75	135	
Weight	1,24	1,26	1,40	2,20	3,10

Dimensions mentioned in mm, weight in kg.

MANUAL GEARBOX WITH HANDWHEEL

ABO gearbox series manual actuators combine state of art production technology, with cast iron and pressed steel construction, to provide a smooth and trouble-free operation for heavy duty on/off and throttling service of ABO valves. The rugged, cast iron body seals weatherproof to IP67. A self-locking gearing holds the valve in the desired position. Further features include a readily accessible handwheel, adjustable stopscrew for closed position, removable splined drive bush with indexing facility and a facility to lock handwheel with padlock and chain. Gearboxes, as well as handlevers, can be supplemented with contacts for endpoint switches.

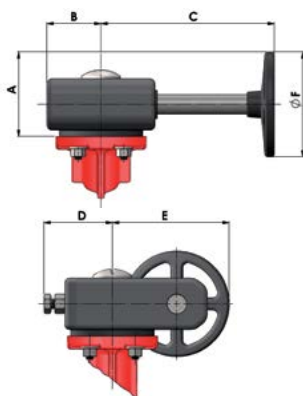

DN	32-100	125-200	250-300	350	400	450-500	600
NPS	1¼-4	5-8	10-12	14	16	18-20	24
A	70	78	134		337	348	448
B	35	46	57		70	110	
C	91	110	156		350	346	441
D	38	46	60		231	196	296
E	84	91	155		369	405	505
F	100		200		600		800
Weight	1,20	2,20	4,20	4,30	6,40	28,00	35,00
Gearbox	242-10M	242-20M	242-30M/22	242-30M/27	242-40M/27-P	AB1250N/F14	AB1250N/F16
Wheel	CD100	CD200		SG300	SG600		SG800

Dimensions mentioned in mm, weight in kg. Valid for series 242 & AB.

ACTUATORS

- **PNEUMATIC ACTUATORS** – ABO pneumatic actuators Series 95 are rack and pinion, opposed-piston actuators available in two versions: single acting & double acting.
- **ELECTRIC ACTUATORS** – ABO Series 97 electric actuators are designed for quarter turn operation. Available in 24VDC, 230VAC/50Hz, 110VAC/60Hz and 3PH 380VAC/50HZ and 440VAC/60Hz.

OPERATING TORQUES [NM] VS. OPERATING PRESSURE [BAR]

DN	32-40	50	65	80	100	125	150	200	250	300	350	400	450	500	600
NPS	1¼-1½	2	2½	3	4	5	6	8	10	12	14	16	18	20	24
pMAX* 6 bar	8	11	15	20	38	55	70	100	160	235	480	750	1180	1380	2050
pMAX* 10 bar	9	12	17	25	46	70	80	125	200	290	530	1200	1550	2050	2700
pMAX* 16 bar	10	14	20	30	55	85	100	150	220	380	580	1650	2100	2700	3750

DN	700	800	900	1000	1200	1400	1600
NPS	28	32	36	40	48	56	64
pMAX* 10 bar	5210	6630	8090	13740	19320	28000	40600

The above mentioned torques are valid for valves with EPDM seat and stainless steel disk only, and under the condition that the working medium is liquid. While actuating the valve, the above mentioned figures should be multiplied by a coefficient of 1.2. Using a NBR seat, it is necessary to apply a coefficient of 1.4. In case the medium is gaseous, or if it contains abrasive particles, it is necessary to apply a secondary coefficient of 1.35. If the working conditions are specific, it is recommended to discuss the selection of the actuator with the manufacturer.

*pMAX - maximum allowable pressure

DIMENSIONS DN 32-1600 (NPS 1¼-64)

DN 32-600 (NPS 1¼-24) PN 6/10/16 // CLASS 150

T – lug type body

B – wafer type body

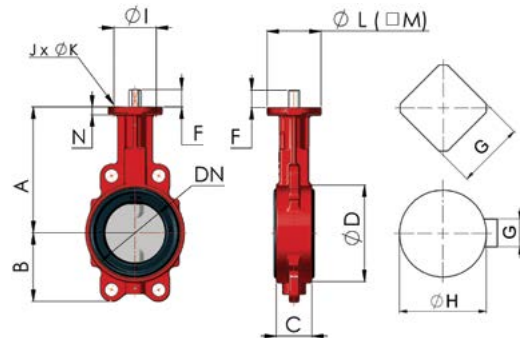
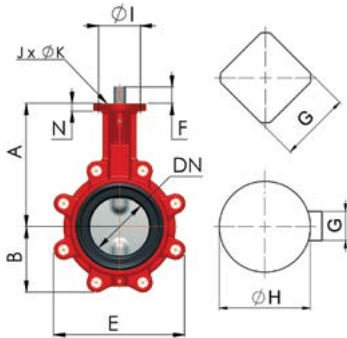

DN		32-40	50	65	80	100	125	150	200	250	300	350	400	450	500	600
NPS		1¼-1½	2	2½	3	4	5	6	8	10	12	14	16	18	20	24
Body type	B														485	565
	T														485	565
Valve dimensions	A	136	146	154	163	173	193	205	234	270	310	325	365	375		
	B	54	64	72	89	105	119	130	166	202	237	271	314	330	368	464
	C	33	43	46		52	56		60	68	78		102	114	127	154
	D	78	96	113	128	150	184	212	268	320	378	435	488	544	590	695
Endshaft dimensions	E	110	115	129	174	204	234	255	319	396	465	509	590	610	682	810
	F	25						30			36			80		
	G	14				17				22		27		10	12	14
ISO flange	H													38	42	50
	I	50				70				102		125	140			165
	J	4														
Flange dimensions	K	7				9				11	14	18			23	
	L	-	70								175			210		
	M	70					70				105	130	140			
Weight	N	8				12		14	17		21	22	27			
	Type B	1,9	2,7	3,2	3,7	4,7	6,7	8,4	13,3	22,0	29,3	46,4	69,8	83,0	112,0	216,0
	Type T	2,3	3,0	3,7	4,8	6,1	9,2	10,2	15,3	28,4	41,2	62,0	96,3	130,0	149,0	288,0
ISO Flange		F05/F07		F05			F07			F10		F12		F14		F16

Dimensions mentioned in mm, weight in kg.

DN 700-1600 (NPS 28-64) PN 10

U – double flanged body (ISO 5752, Series 20)

DN		700	800	900	1000	1200	1400	1600
NPS		28	32	36	40	48	56	64
Body type – U	A	629	666	720	800	940	1009	1150
Valve dimensions	B	537	601	656	720	844	1014	1045
	C	165	190	203	216	254	279	318
	D	840	950	1050	1160	1380	1590	1820
Endshaft dimensions	F	95		130		150		180
	G	16	20	22	28	32	40	
	H	55	75	85	105	120	160	
	M	63	84	95	117	134	178	
ISO flange	I	254			298	356		
	J	8						
	K	18			22	33		
	L	300			350	415		
Weight	350	580	700	850	1080	1922	2350	
ISO Flange	F25			F30	F35			

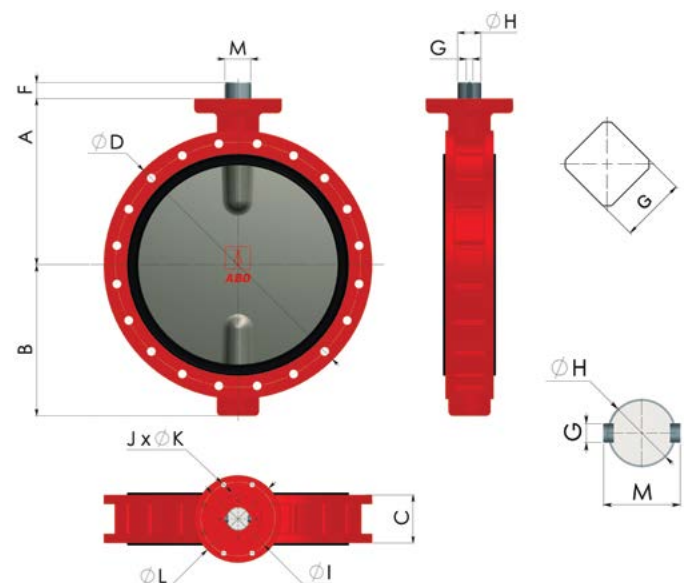

Dimensions mentioned in mm, weight in kg. Version PN 16/ Class 150 upon request.

DESIGN BENEFITS OF F-TYPE BODY VALVES

INTERNATIONAL STANDARD FLANGE

Top flange designed according to standard ISO 5211 enables direct mounting of manual operators and actuators. This solution ensures simple installation of actuator in the field, minimizes possible misalignment, and reduces overall height.

EXTENDED NECK

Longer neck of ABO double flanged butterfly valves series 900 results in insulation of mounted actuator from thermal influence of transported media and thus meets heating system regulation requirements.

BLOW-OUT PROOF SYSTEM

Upward movement of the shaft is eliminated by safety retainer in the body neck.

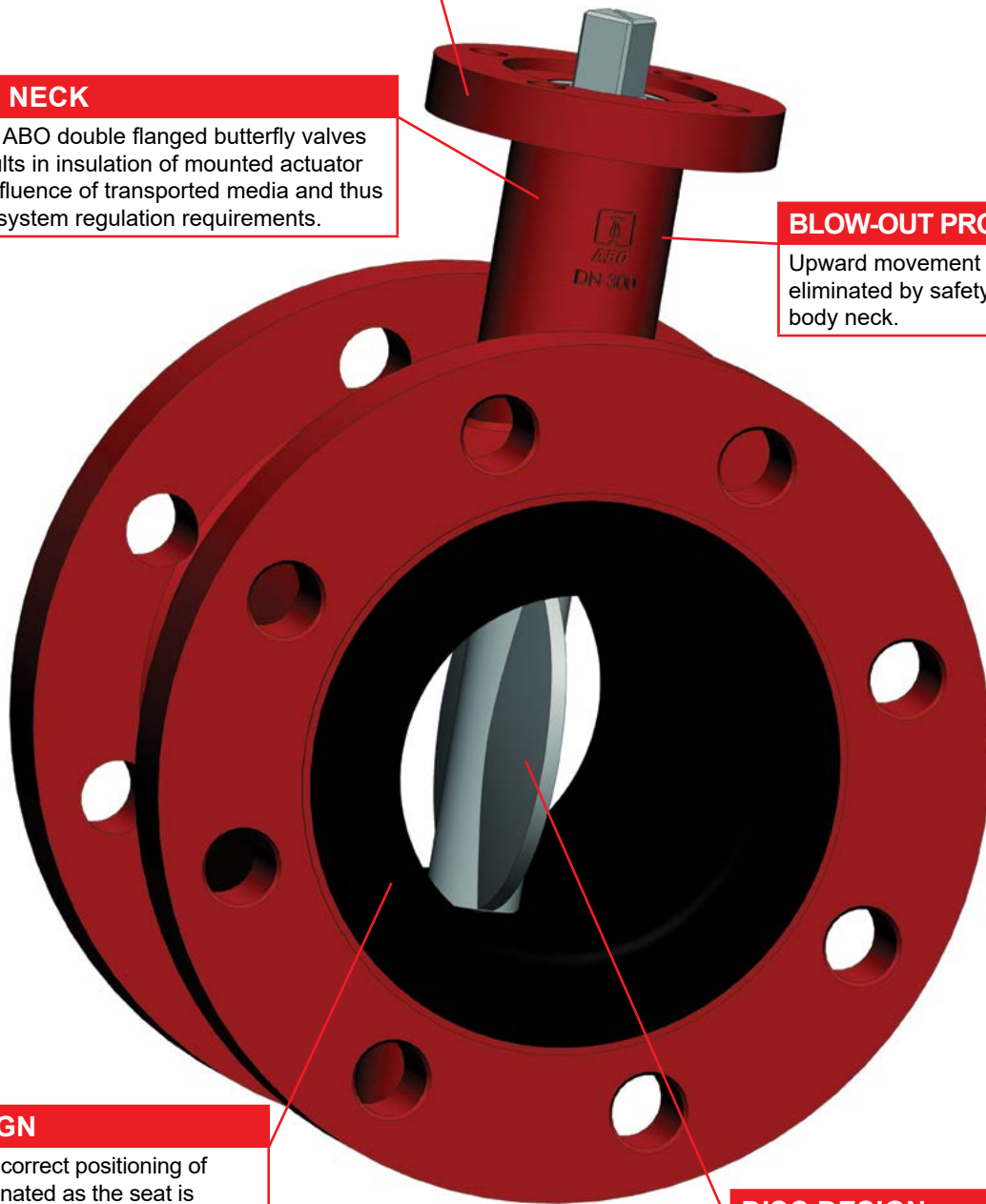

SEAT DESIGN

Movement or incorrect positioning of the seat is eliminated as the seat is vulcanized directly on the valve body. The prime advantage of this solution is longer service life of the valve. Furthermore, this feature leads to the reduction of torque values that are needed to operate the valve, which ultimately generates savings on the actuation solutions. Finally, since the inner part of the valve is fully lined by rubber, the body is protected against the corrosive influence of the aggressive media.

DISC DESIGN

The spherically machined disc with polished edges is gentle to the liner, provides a long service-life, bi-directional bubble-tight shut-off, and minimized torque values needed to operate the valve. The symmetrical disc profile enhances valve performance with an increase in Kv (Cv) values. Further, it reduces turbulence and minimizes pressure drops.

ACTUATION, TORQUES & COATING OPTIONS OF F-TYPE BODY VALVES

ACTUATION POSSIBILITIES

All ABO handles, manual gear operators, pneumatic and electric actuators can be mounted directly to ABO butterfly valves, thus eliminating brackets or couplings. This allows for simple installation in the field, minimizes possible misalignment and decrease overall height.

MANUAL ACTUATION: HANDLEVER

For manual actuation, ABO offers levers made of carbon steel material with premium protective coating for excellent corrosion, abrasion and impact resistance. A lever made of stainless steel material is also an option. Connection to the top flange meets ISO 5211 standards. F05 size connection is used to control DN 50 and 65 valves and F07 size of top flange connection is used to control DN 80–200 valves, respectively.

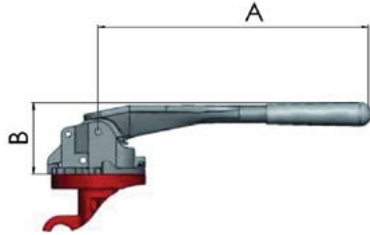

DN	50–100	125	150–200	250	300
NPS	2–4	5	6–8	10	12
A	270		362	450	750
B	75	75	75	135	
Weight	1,24		1,40	2,20	3,10

Dimensions mentioned in mm, weight in kg.

MANUAL ACTUATION: GEARBOX WITH HANDWHEEL

ABO gearbox series manual actuators combine state of art production technology, with cast iron and pressed steel construction, to provide a smooth and trouble-free operation for heavy duty on/off and throttling service of ABO valves. The rugged, cast iron body seals weatherproof to IP67. A self-locking gearing holds the valve in the desired position. Further features include a readily accessible handwheel, adjustable stopscrew for closed position, removable splined drive bush with indexing facility and a facility to lock handwheel with padlock and chain. Gearboxes, as well as handlevers, can be supplemented with contacts for endpoint switches.

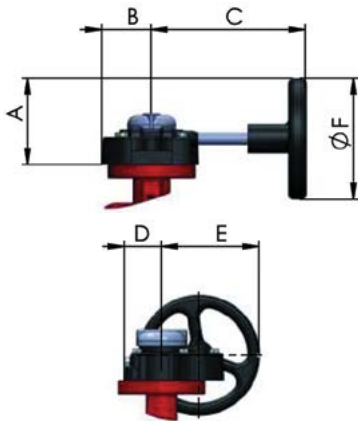

DN	50–125	150–300	350	400	450–500	600
NPS	2–5	6–12	14	16	18–20	24
A	89	155	225	275		350
B	51	66	99		126	158
C	152	252	245	285	337	382
D	44	59	96		118	145
E	101	177	265	315	348	454
F	125	250	350	450		600
Gearbox	SE07	SE10	M14		M15	M16
Weight	1,6	3,7	6,6		14,5	27,2

Dimensions mentioned in mm, weight in kg.

ACTUATORS

- **PNEUMATIC ACTUATORS** – ABO pneumatic actuators Series 95 are rack and pinion, opposed-piston actuators available in two versions: single acting & double acting
- **ELECTRIC ACTUATORS** – Series 97 electric actuators are designed for quarter turn operation. Available in 24VDC, 230VAC/50Hz, 110VAC/60Hz and 3PH 380VAC/50HZ and 440VAC/60Hz.

OPERATING TORQUES VS. OPERATING PRESSURE (NM)

DN	50	65	80	100	125	150	200	250	300	350	400	450	500	600	
NPS	2	2½	3	4	5	6	8	10	12	14	16	18	20	24	
pMAX* 10 bar	wet	13,9	15,4	21,7	37,1	57,9	93,9	173	286	429	550	755	1012	1350	2111
	dry	22,1	29,2	41,1	67,8	101,0	165,0	297	486	699	825	1133	1518	2025	3166
pMAX* 16 bar	wet	15,1	17,2	23,1	39,8	61,9	102,0	192	323	490	625	846	1131	1431	2301
	dry	24,2	32,7	43,7	72,8	108,0	174,0	330	549	799	959	1307	1787	2288	3711

*pMAX - maximum allowable pressure

1. Torques mentioned above are intended for use under normal conditions. Values don't include a safety factor.
2. Normal use means a clean medium, a temperature of from -4,5°C to 93°C, no precipitation in the valve or chemical attack. The valve must be operated at least once a day.
3. Torques in the table are meant regardless of the dynamic torque factor.
4. The safety factor must be considered before selecting the actuator.
5. The above mentioned torques are valid for valves with EPDM seat only. For reliable control of the valve by the actuator, the above data should be multiplied by the factor 1,2. If a seat of NBR material is used, the value should be multiplied by a factor of 1,25.
6. If the working conditions are specific, it is recommended to discuss the selection of the actuator with the manufacturer

MATERIALS & DIMENSIONS F-TYPE BODY VALVES DN 50-300 (NPS 2-12)

DN 50 – 300 (NPS 2 – 12)

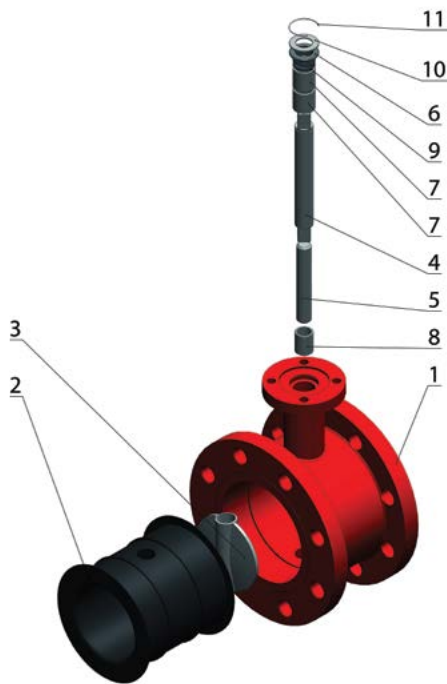

Item	Name	Material
1	Body	Ductile iron 0.7040 (EN-GJS-400-15)
2	Seat	1 – NBR vulcanized 2 – EPDM vulcanized
3	Disc	2 – Stainless steel 1.4308 (CF8) 3 – Ductile iron 0.7040 (EN-GJS-400-15) 4 – Stainless steel 1.4408 (CF8M)
4	Shaft	Stainless steel 1.4021 (AISI 420)
5	Pivot	Stainless steel 1.4021 (AISI 420)
6	Bushing	Stainless steel 1.4021 (AISI 420)
7	Bushing	PTFE
8	Bushing	PTFE
9	O-ring	NBR / EPDM (depending on seat material)
10	Circlip for hole	Stainless steel
11	Clamp Spring	Stainless steel

Other material execution can be provided upon request. The choice of seat and disc material will be recommended for specific media after a specific query. Maximum temperatures for each seat material are acceptable only for specific medium and for a short exposure time. Please always consult with the manufacturer for material selection.

DN	50	65	80	100	125	150	200	250	300
NPS	2	2½	3	4	5	6	8	10	12
A	131	142	155	168	184	202	241	272	308
B	84,0	85,0	92,5	108,5	121,5	138,0	161,5	195,0	222,0
H	25								
□E	14			17			22		
∅O	55					70			
h	3								
∅K	90					125		140	
ISO5211	70					102			
n × ∅N	4-∅7			4-∅9		3-∅10,5; 1-M10		4-∅10,5	

DN	50	65	80	100	125	150	200	250	300	
NPS	2	2½	3	4	5	6	8	10	12	
L	108	112	114	127	140		152	165	178	
∅C	PN10	125	145	160	180	210	240	295	350	400
	PN16	125	145	160	180	210	240	295	355	410
∅D	PN10	165	185	200	220	250	285	340	395	445
	PN16	165	185	200	220	250	285	340	405	460
N × ∅M	PN10	4-∅19				4-∅23			4-∅28	
	PN16	4-∅19				4-∅23			4-∅28	
a°	PN10	45,0			22,5				15,0	
	PN16	45,0			22,5				15,0	

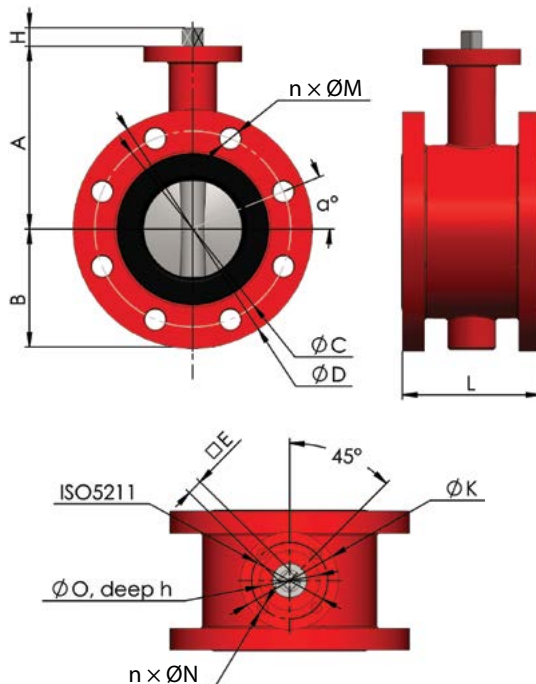

MATERIALS & DIMENSIONS F-TYPE BODY VALVES DN 400-600 (NPS 16-24)

DN 400-600 (NPS 16-24)

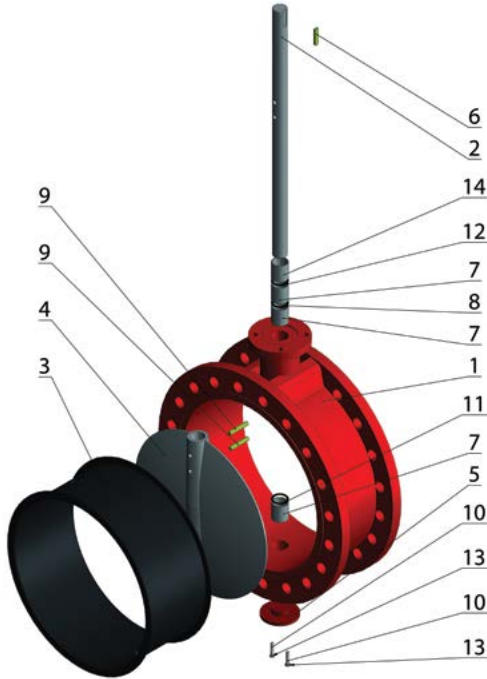

Item	Name	Material
1	Body	Ductile iron 0.7050 (EN-GJS-500-7)
2	Shaft	Stainless steel 1.4401 (316)
3	Seat	1 – NBR vulcanized 2 – EPDM vulcanized
4	Disc	Ductile iron 0.7050 (EN-GJS-500-7)
5	Lower Cover	Ductile iron 0.7050 (EN-GJS-500-7)
6	Key	Stainless steel 1.0060
7	Bushing	Bronze
8	O-ring	NBR/EPDM (depending on seat material)
9	Pin	Stainless steel 1.4401 (316)
10	Bolt	Zinc coated steel / Stainless steel
11	O-ring	NBR/EPDM (depending on seat material)
12	O-ring	NBR/EPDM (depending on seat material)
13	Washer	Zinc coated steel / Stainless steel
14	Bushing	Bronze

Other material execution can be provided upon request. The choice of seat and disc material will be recommended for specific media after a specific query. Maximum temperatures for each seat material are acceptable only for specific medium and for a short exposure time. Please always consult with the manufacturer for material selection.

DN	400	450	500	600	
NPS	16	18	20	24	
ØD	580	640	715	840	
ØD1	PN10	515	565	620	725
	PN16	525	585	650	770
N-ØD0	PN10	16-Ø28	20-Ø28	20-Ø31	
	PN16	16-Ø31	20-Ø31	20-Ø34	20-Ø37
H	52		64	70	
H1	375	405	450	518	
H2	292	307	342	433	
H3	45	45	55	65	
ØE	33,15	38,00	41,15	50,65	

DN	400	450	500	600
NPS	16	18	20	24
n-b	1-10		1-12	2-16
ØA	175			210
ØB	140			165
h	4			
ØC	100			130
N1-ØD1	4-Ø18			
L	216	222	229	267
L1	221	227	234	272
f	28,0	30,0	31,5	36,0
S	36,15	41,00	44,15	54,65

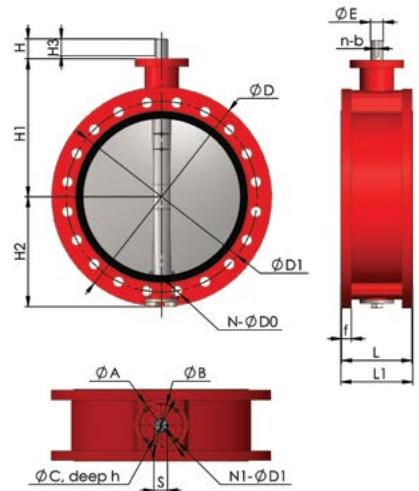

EUROPEAN UNION
European Regional Development Fund
Operational Programme Enterprise
and Innovations for Competitiveness

All statements, technical information in this brochure are tentative and for general use only and do not constitute a recommendation or guarantee for any specific service or application requirement. Consult ABO representative or factory for specific requirements and material selection for your intended application. The right to change or modify product design or product without prior notice is reserved. Binding specification will be provided in each offer. ABO valve accepts no liability for damages caused by bad interpretation or use of the information included in this brochure.

1. 8. 2017

Data subject to change.

Company HQ – Czech Republic:
ABO valve, s.r.o.
Dalimilova 285/54, 783 35 Olomouc
Tel.: +420 585 224 087
Email: export@abovalve.com
www.abovalve.com

USA:
ABO Controls, LLC
Houston, Texas
Tel.: +1 (281) 930-7126
Email: salesUSA@abovalve.com
www.abocontrols.com

Singapore:
ABO Valve Pte. Ltd.
Singapore
Tel.: +65 9169 4562
Email: lsw@abovalve.com
www.abovalve.com

Slovakia:
ABO Slovakia s.r.o.
Banská Bystrica
Tel.: +421 484 145 633
Email: aboslovakia@aboslovakia.sk
www.aboslovakia.sk

Bahrain:
ABO Middle East
Manama
Tel.: +973-3444 9065
Email: jimminen@abovalve.com
www.abovalve.com

United Arab Emirates:
ABO UAE
Abu Dhabi
Tel.: +971 56 9207964
Email: bharti@abovalve.com
www.abovalve.com

Germany:
ABO Armaturen GmbH
Mönchengladbach
Tel.: +49 2166 3101676
Email: salesDE@abovalve.com
www.abo-armaturen.de

Russia:
ABO ARMATURA LLC
Smolensk
Tel.: +7 (4812) 240 020
Email: aboarmatura@yandex.ru
www.aboarmatura.ru

Brazil:
ABO do Brasil Válvulas
Industriais Eireli
Valinhos
Email: export@abovalve.com
www.abovalve.com

Ukraine:
ABO Ukraine LLC
Dnipro
Tel.: +38 056 733 95 70
Email: a.maruschak@abovalve.com
www.abovalve.com.ua

Turkey:
ABO Armaturen LTD 5TI
Istanbul
Tel.: +90-216 527 36 34
Email: m.sahin@abovalve.com
www.abovalve.com

China:
ABO Flow Control
Shanghai
Tel.: +86 13601522831
Email: wen@abovalve.com
www.abovalve.com

India:
ABO Controls Pvt. Ltd.
Mumbai
Tel.: +91 99 2002 9994
Email: dsouza@abovalve.com
www.abovalve.com