

SERIES 2000

Single seated top guided control valve

SERVICE

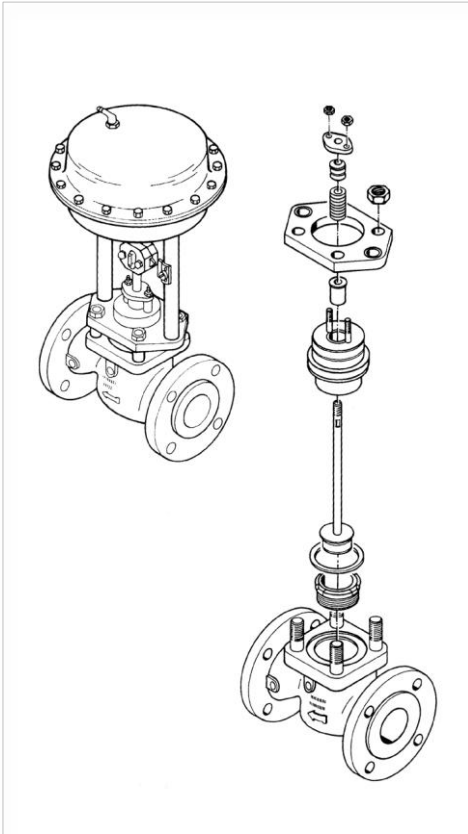

Fig. 1 Series 2000 valve assembly

Preventive maintenance

Preventive maintenance consists of making a periodic visual inspection of the valve assembly. This will reveal packing box leaks, loosening of air connections due to vibration and other visible failures of valve parts and accessories. A suggested inspection includes the following actions:

1. Check packing box for leakage. If leakage is evident, do not tighten packing flange nuts beyond point required to stop leakage. If packing box is too tight (this can very easily happen when a wrench is used), excess stem friction is created due to the pressure of packing against stem. The excess stem friction may cause the diaphragm top to require several additional pounds of air to stroke the valve. If tightening the packing flange nuts fails to stop the leakage, box requires either additional packing or removal of the old packing and installation of a new one.
Periodic cleaning of the valve stem will keep dirt and grit from being carried into packing.
2. Check all mechanical and air connections. In some applications, e.g. where the valve is located in a line near a pump, vibrations may cause both, mechanical and air connections to work loose.
3. If possible, stroke the valve through several cycles, noting the pressure required for stroking and normal action of the valve.
4. Check tightness of diaphragm case (seal and o-ring)
5. Check tightness of screws connections body bonnet
6. Check tightness of actuator post nuts.
7. Check tightness of stem connector.

Overhauling procedure

Valve overhaul requires disassembling the valve body.

WARNING. Depressurize the line to atmospheric pressure and drain all fluids before working on the valve.

Make a thorough inspection of the plug, seat ring and stem to determine whether these parts should be re-used, reworked or replaced.

Note

For an easy inspection of the valve trim, the bonnet may be removed from the valve body with the actuator still mounted and attached to the valve stem.

To minimize the possibility of leakage, always replace the valve body gaskets whenever the valve is disassembled.

Actuator removal

1. Disconnect actuator and valve stem by removing stem clamp bolts and clamp.

Note

On reverse actuators the preadjusted spring force is effective. Therefore apply enough air pressure to the actuator to stroke the stem to middle position (50% stroke) before disconnecting actuator and valve stem.

2. Reduce the loading pressure in the actuator to atmosphere.
3. Disconnect the pneumatic connection to the actuator.
4. Remove the two hexagon nuts from the actuator.
5. Lift actuator off valve.

Mounting actuator on valve

1. Push the valve stem down by hand to fully close the valve.
2. Replace the complete actuator, locating the actuator rods in the holes on the bonnet bridge piece and fit the hexagon nuts to the rods without completely tightening the nuts.
3. Connect the adjustable air supply to the actuator.
4. On direct acting actuator (Figure 8) apply sufficient air pressure to the actuator to fully stroke the actuator to nominal stroke plus 5%.
5. On reverse acting actuator (Figure 9) apply sufficient pressure to the actuator to start point (eg. 0,5 bar).
6. Attach the stem connector as this point making sure that the stroke indicating pointer faces the lowest marking on the stroke indicator plate with the plug in the fully closed position. Tighten the stem clamp cap screws fully.
7. Completely tighten the actuator rod nuts securing the actuator firmly to the valve.
8. Fine adjustment may be made (with the plug off the seat) by slightly slackening the plug stem towards or away from actuator stem (Figure 10) using spanners fitted to the flats provided on both stems for this purpose.
9. Readjust the travel indicator plate as necessary

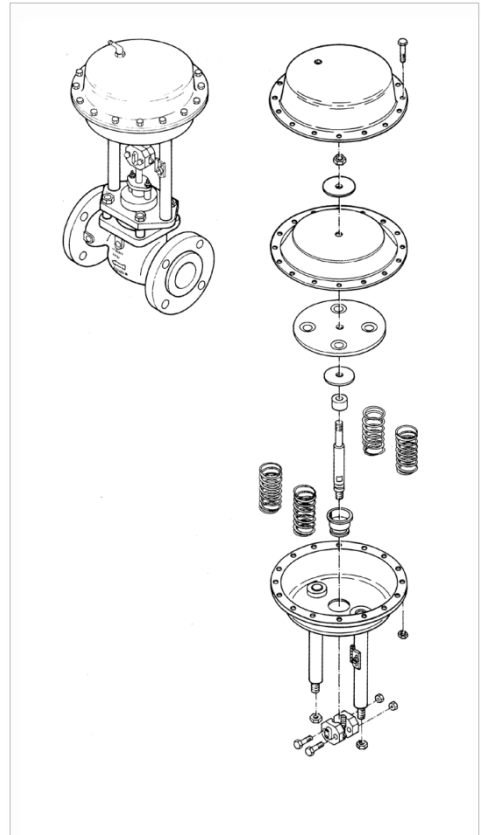

Fig. 2: Series 2000, actuator assembly

Valve service

Replacing plug

1. Disconnect actuator and valve stem by removing stem clamp bolts and clamp.

Note

On reverse actuators the preadjusted spring force is effective. Therefore apply enough air pressure to the actuator to stroke the stem to middle position (50% stroke) before disconnecting actuator and valve stem.

2. Reduce the loading pressure in the actuator to atmosphere.
3. Disconnect the pneumatic connection to the actuator.
4. Remove nuts securing bonnet to valve body.
5. Lift off the bonnet along with the actuator, valve plug and stem.
6. Loosen the packing box gland nuts until they are just finger tight.
7. Remove the plug and stem assembly from bonnet. A replacement plug and stem assembly may now be fitted if required. When withdrawing or replacing the valve stem use a gentle turning motion to avoid damage to the packing material.

Replacing seat ring

1. Remove the actuator, bonnet and plug from the valve body (see “replacing plug procedure” 1 to 5).
 2. Remove seat ring and fit replacement using a suitable seat ring tool (Figure 3).
- The application of a high performance lubricant is recommended.
When refitting the seat ring, MoS₂ additives are also advantageous if compatible with the process fluid.

Replacing sealing of soft seat plug (DN 125 and DN 150)

1. Disassemble the valve as shown “replacing plug procedure” 1 to 7
2. Loosen the screws and remove clamp ring (Figure 6).
3. Replace sealing ring.
4. Screw clamp ring with plug. The sealing ring must be pressed until the metallic stop of the clamp ring.
5. Assemble the valve in reverse order.

Lapping plug and seat ring

1. The sealing surfaces can be improved by using a good quality carborundum paste with 280 grit size.
2. Apply lapping compound to seating surfaces of plug and seat ring.
3. Lap plug into seat ring (Figure 4) to obtain good seating surfaces on both. Do not remove too much metal. Stop lapping after seating surfaces of 1/32 inch (0,8 mm) wide has been obtained in seating of plug. Check the correct seating of the plug.
4. Remove all traces of lapping compound from sections of the plug and seat ring completely.

Packing replacement

1. Disconnect actuator and valve (see “replacing plug” 1 to 2).
2. Remove packing gland packing nuts, flange and follower. Pull out packing with a hook, being careful to avoid scratching the packing box wall.
3. Clean packing box and all metal parts.
4. Install new packing (Figure 5) and associated parts in correct sequence and replace the packing flange and nuts. With PTFE spring loaded packing, tighten gland nuts until limited by travel stop, fitted to the packing. In case of PTFE or graphite packing, tighten just enough to prevent leakage.

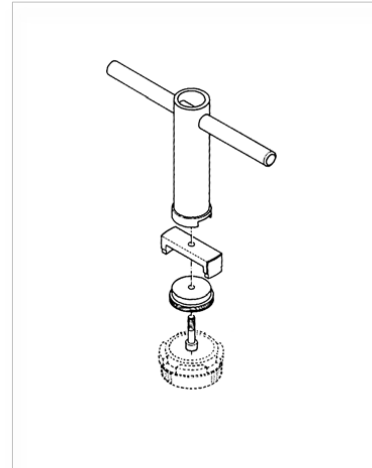

Figure 3: seat ring tool

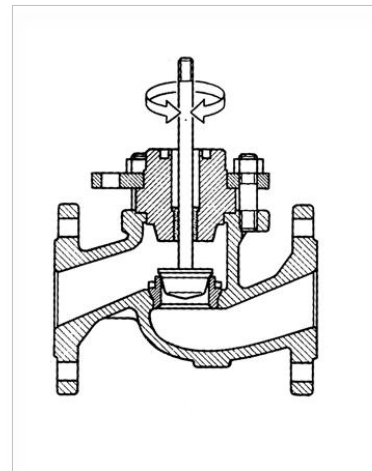

Figure 4: Lapping plug into seat ring

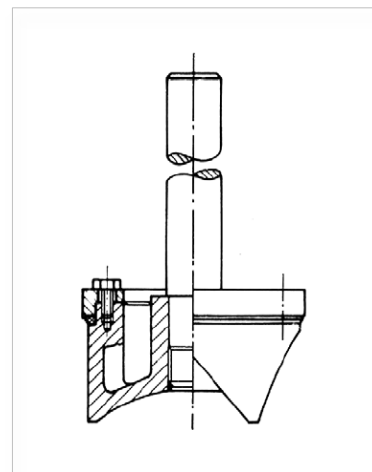

Figure 6: Soft seat plug

Replacing of bellows seal

NOT: The plug stem must NOT be rotated or damage to the bellows assembly will result!

1. Follow the “replacing plug procedure” steps 1 to 5 to remove the complete bellows seal bonnet (Figure 7) and bonnet packing assembly from the valve body.
2. Loosen the packing gland nuts in the case of adjustable bonnet packing. Separate the packing bonnet from the bellows seal housing by removing the hexagon nuts and then remove the packing bonnet using a turning motion to avoid damage to the packing due to the threads of the valve stem.
3. Pull the valve plug stem out of the guide bushing until the pin securing the plug to the stem is revealed. Remove the pin and unscrew the plug from the stem.
4. Bellows seal / valve stem assembly may now be withdrawn from the bellows seal housing. Examine for any indication of leakage or damage and replace with new assembly if necessary using new flat gaskets throughout.
5. Reassemble in reverse order. Drill new hole through plug and valve stem at right angle to old hole in stem. Size of new hole to be appropriate to allow force fitting of new pin. Prior to refitting actuator test for efficiency of bellows seal by applying 5 bar air pressure to the valve body and checking for any leakage at the test connection provided below the packing chamber.

Reversing valve action

1. Remove the stem clamp and disconnect the air supply (see “replacing plug procedure” 1 to 3).
2. Remove the short bolts around the diaphragm chamber. Gradually loosen each of the long bolts, factory fitted with warning labels, slackening each bolt, factory fitted with warning labels, slackening each bolt alternatively by one or two turns to progressively relieve the compression of the actuator springs inside the chamber.

WARNING: Long bolts must always be removed last to ensure that the spring compression is fully released before the diaphragm upper casing is removed! Risk of injury!

3. Remove the diaphragm upper casing.
4. Remove the actuator stem nut, using a spanner on the flats provided on the lower end of the stem to prevent rotation. The clamp plates, diaphragm, spring plate, spacer and springs may now be removed.
5. Assemble the internal parts in accordance with Figure 8 (directing) or figure 9 (reverse acting). Follow above disassembly procedure 1 to 4 in reverse sequence. Ensure that the actuator springs are evenly distributed inside the casing and vertically located by the spring buttons of the diaphragm plate.

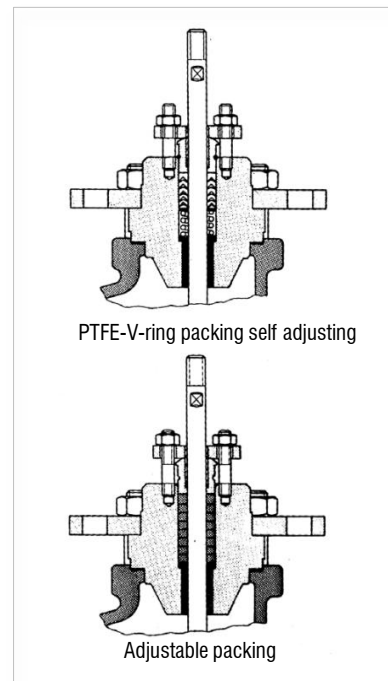

Figure 5: Packing

Reversing valve action of Tandem actuator Series 2000

1. Remove actuator from valve. Disassemble at first the upper actuator chamber and then the lower actuator chamber. (see „reversing valve action procedur“ 1 to 4).
2. Remove both chambers in the middle.
3. Remove complete actuator stem. Remove pin securing the connection of the stems. Unscrew the stems.
4. Remove all parts (Spring plate, counterpart, springs, spacer, diaphragm)
5. Reassemble all internal parts acc. Figure 11 (direct or reverse acting) following 1 to 4 in reverse order.

Note: It is absolutely necessary that the springs are uniformly distributed in the chamber. They have to be in right angle to the spring plate!

Actuator service

Replacing the actuator diaphragm

1. Remove the stem clamp and disconnect the air supply (see “replacing plug procedure” 1 to 3).
 2. Remove the short bolts around the diaphragm chamber. Gradually loosen each of the long bolts, factory fitted with warning labels, slackening each bolt alternatively by one or two turns to progressively relieve the compression of the actuator springs inside the chamber.
- WARNING: Long bolts must always be removed last to ensure that the spring compression is fully released before the diaphragm upper casing is removed!**
Risk of injury!
3. Remove the diaphragm upper casing.
 4. Remove the actuator stem nut, using a spanner on the flats provided on the lower end of the stem to prevent rotation. The clamp plates, diaphragm, spring plate, spacer and spring may be removed.
 5. Use a new actuator diaphragm and assemble the internal parts in accordance with Figure 8 (direct action) or Figure 9 (reverse action). Follow above disassemble procedure 1 to 4 in reverse order. Ensure that the actuator springs are evenly distributed inside the casting and vertically located by the spring buttons of the diaphragm plate.

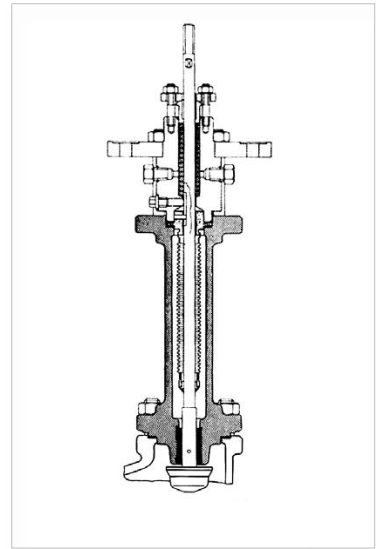

Fig. 7: Bellows seal bonnet

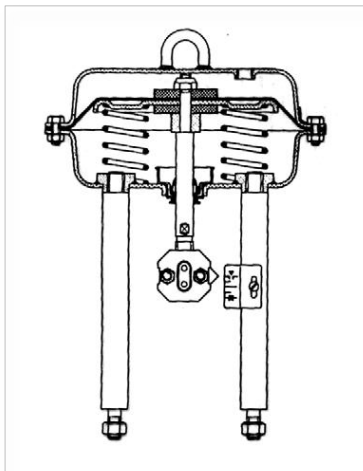

Fig. 8: actuator direct acting

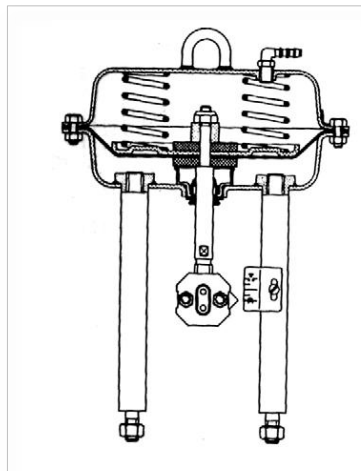

Fig. 9: actuator reverse acting

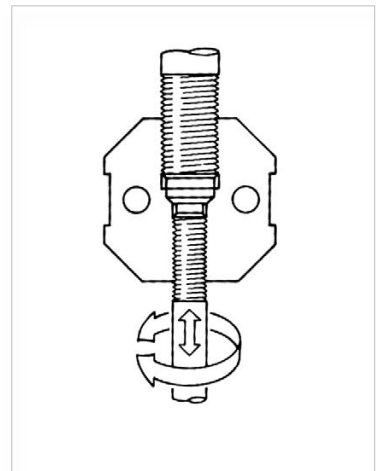

Fig. 10: Stem clamp, connection between actuator and valve stem

Replacing of stem seal

1. Disassemble actuator as described in “replacing of actuator diaphragm procedure” 1 to 4.
2. Remove actuator from the valve by removing the hexagon nuts from the two actuator rods.
3. Withdraw the actuator stem through the bottom of the diaphragm lower case.
4. Renew the stem seal and replace the actuator stem from below through the bottom of the lower case after applying silicone based grease to the two chambers in the stem seal.
5. Reassemble the actuator as described in “reversing valve action procedure”, point 5.

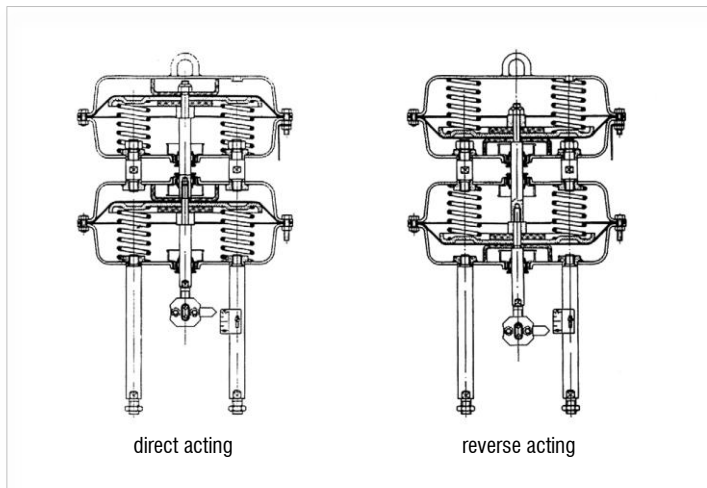

Fig. 11: actuator assembling Series 2000T, tandem

Spring compression adjustment

The valve stroke is adjusted simply by altering the distance between the end of the plug stem and actuator stem within the split stem clamp (Figure 10).

1. Remove the stem clamp by following “actuator removal procedure” 1 to 3.
2. Adjust the valve stroke by following “mounting actuator on valve procedure” point 1, 3 to 6, 8 and 9.

Connection air supply

On valves without positioner, the control air signal line is connected directly to the appropriate actuator air chamber. On a direct acting actuator (air –to–close), the control air line is connected to the upper, and on a reverse acting actuator (air-to-open) to the lower actuator chamber. On actuator with positioner the interconnecting piping between positioner and actuator is factory installed.

A suitable air supply must be piped to the supply port of the positioner. If an airset is factory fitted the piping between airset and positioner supply port is factory installed and the air supply must be piped to the airset.

Air connections are 1/ inch NPT. Use of non-matching fittings may result in damaged threads and leaks.

Caution!

Do not tamper with pressure regulator adjustment. Reduced outlet pressure may be insufficient for valve operation, while increased pressure may damage the valve.

Pressure limits for the various valve-and-actuator combinations are listed in Specification Sheet.

Checking operation

The valve is adjusted and tested at the factory before shipment and should require no further adjustment in the field. After installation, use a regulated air supply to stroke the valve through several cycles to ensure that it operates smoothly.

GENERAL SAFETY INFORMATION

Using of Valves and Actuator, manufactured by A. Hock MSR- u. Electronic Service GmbH (shortened "HOCK") in accordance regulations.

Terms concerning safety

The safety terms DANGER, WARNING, CAUTION and NOTE are used instructions to highlight particular danger and/or to provide additional information on aspects that may not be readily apparent.

DANGER: indicates that death, severe personal injury and/or substantial property damage will occur if proper precautions are not taken.

WARNING: indicates that death, severe personal injury and/or substantial property damage can occur if proper precautions are not taken.

CAUTION: indicates that minor personal injury and/or property damage can occur if proper precautions are not taken.

NOTE: indicates and provides additional technical information, which may not be very obvious even to qualified personnel. Compliance with other, not particularly emphasised notes, with regard to transport, assembly, operation and maintenance and with regard to technical documentation (e.g. in the operation instruction, product documentation or on the product itself) is essential, in order to avoid faults, which in themselves might directly or indirectly cause severe personal injury or property damage.

Using

The following instructions are designed to assist in unpacking, installing and performing maintenance. Product users and maintenance personnel should thoroughly review this bulletin prior to installing, operating or performing any maintenance.

DANGER, risk of injury! In most cases HOCK-valves and actuators are designed for specific applications (e.g. with regard to medium, pressure, temperature). For this reason they should not be used in other applications without first consulting the manufacturer.

Protective clothing

HOCK-valves and actuators are often used in problematic applications (e.g. extremely high pressures, dangerous, toxic or corrosive mediums). In particular valves with bellows seals point to such applications. When performing service, inspection or repair operations always ensure, that the valve and actuator are depressurised and that the valve has been cleaned and is free from harmful substances. In such cases pay particular attention to personal protecting (protective clothing, gloves, glasses etc.).

Qualified personnel

Qualified personnel are people who, on account of their training, experience and instruction and their knowledge of relevant standards, specifications, accident prevention regulations and operating conditions, have been authorized by those responsible for the safety of the plant to perform the necessary work and who can recognize and avoid possible dangers.

Spare parts

Use only HOCK original parts. HOCK cannot accept responsibility for any damages that occur from using spare parts or fastening materials from other manufactures. If HOCK products (especially sealing materials) have been on store for longer periods check these for corrosion or deterioration before using these products.

Unpacking

Each delivery includes a packing slip. When unpacking, check all delivered valves and accessories using this packing slip. Larger valves can be lifted using slings in the yoke or if present, using the lifting lugs or eyebolt connections provided for the purpose. If slings are used, attach them so that the other tubing or attaching parts are not damaged.

WARNING

If slings are used, be aware that the centre of gravity of the valve be above the lifting point. In this case, secure or support the valve rotating, to prevent damage or personal injury.

Report transport damage to the carrier immediately. In case of discrepancies, please contact A. Hock MSR-u. Electronic Service GmbH.

Installation

DANGER

Before installation check the order-no. and/or the tag-no. to that the valve/actuator is correct for the intended application.

Do not insulate extensions that are provided for hot or cold services.

Pipelines must be correctly aligned to ensure that the valve is not fitted under tension. Fire protecting for HOCK products must be provided by the end user.

NOTE

According to the Pressure Equipment Directive the HOCK Valves must not be installed as an accessory with safety function.

Commissioning

Clean tubing prior to installing.

If possible, install the valve in an upright position (actuator on top), to ease maintenance. An upright installation position is important with low-temperature applications, in order to keep the distance between the packing material and the medium as large as possible. The packing material then retains the ambient temperature as much as possible.

NOTE

Observe the diminished pressure curve when overstepping the specified border temperature.

NOTE

Do not insulate extensions bonnets that are provided for hot or cold services.

Make sure that sufficient overhead clearance above the actuator is maintained, to allow for disassembly of plug from the valve body. See installation, Operating and Maintenance manual (IOM) for detailed information.

After installing, check direction of flow again. The direction of flow is shown by the arrow on the valve.

If the valve is to be welded into the line, make sure that the valve is shielded from excessive heat.

Welding must be performed by qualified welders.

Connecting supply pressure and signal lines

Control valves are supplied with a positioner. The end connections for supply pressure and signal are clearly marked. Actuator and positioner are suitable for max. supply pressure as detailed on the product and within the applicable IOM's. If the supply pressure exceeds the pressure specified, a pressure reducing station is required. If instrument air is not available, install an oil separator/air filter in the air inlet line. All connections must be leak free.

QUICK CHECK

Before operating, check the valve as follows:

Open and close the valve, and observe the moment of the actuator stem. The movement must be smooth. Check maximum stroke through change of signal (ie pneumatic/electrical signal).

Check all air connections for leaks.

Check packing nut(s) for proper tightness. Packing nut(s) should be slightly over finger-tight; however, tighten only as necessary to prevent stem leakage (see appropriate IOM for details).

NOTE

An excessively tightened packing can cause excessive packing wear and can hinder of the plug stem.

Check fail-safe position. To do this, close supply pressure and/or electrical signal and observe whether the valve open or closes defined.

If temperature cycling occurs, re-tighten all bolt connections and packing as necessary and check for leaks.

General maintenance

To avoid possible injury to personnel or damage to products, safety requirements and local health and safety rules must be strictly adhered to. Modifying this product, substituting non-factory parts, or using maintenance procedures other than outlined in this instruction could drastically affect performance and be hazardous to personnel and equipment, and will void existing warranties.

DANGER, risk of injury. Between actuator and valve there are moving parts. To avoid injury all hands, hair and clothing away from all moving parts when operating valve.

Welding to repair or to connect the valve may only be performed by trained and qualified welding personnel. Apart from the operating instructions and the obligatory accident prevention directives valid in the country of use, all recognised regulations for safety and good engineering practices must be followed.

WARNING

BEFORE valves are returned to HOCK for repair or maintenance take care that the product is free of medium and clean.

Storage

HOCK products are manufactured from various materials. Products not manufactured resistant materials are provided with an appropriate protection. This means that HOCK products are well protected from corrosion. Nevertheless HOCK products must always be adequately stored in clean, dry environment. Plastic caps fitted to the flange faces to prevent the ingress for foreign materials. These caps should not be removed until the valve actually mounted into the system.

Valve and actuator variations

These instructions cannot claim to cover all details of all possible product variations, nor in particular can they provide information for every possible example of installation, operation or maintenance. This means that the instructions normally include only the directions to be followed by qualified personnel where the product is being used for its defined purpose. If there are any uncertainties in this respect particularly in the event of missing product-related information, clarification must be obtained at HOCK.

Periodic maintenance

Check valves for correct functioning at regular intervals (depending on the application and criticality) as follows. This check can be made when installed and in many cases without interrupting production. Examine gaskets for leaks and if necessary retighten fasteners.
Check bellow gaskets and test connection - if present - for external leaks.
Check valve for damage caused by corrosive residues or corrosive vapours.
Clean valves and if necessary repaint.
Check glands for leakage. Adjust as necessary. See Installation, Operating and Maintenance manual (IOM) for detailed information.

NOTE

An excessively tightened gland nut can cause excessive packing wear and can hinder the free movement of the plug stem.

If possible, open and close valve and check for maximum stroke and smooth movement of the plug stem. Irregular movement of the plug stem may indicate internal defects.

NOTE

With graphite packing, irregular movement of the plug stem is possible.

DANGER, risk of injury. Keep hands, hair, clothing, etc. away from all moving parts. Failure to do so can lead to serious injury.

Check all accessories for firm seating.

If possible, close supply pressure and check the fail-safe position.

Check stems boot wear.

Check actuator for leaks. To do this, spray housing, air connections and plug stem guide with leak spray and check for any bubble formation.

Clean plug stem.

Check air filter, if present, and if necessary replace insert.

NOTE

For further information please contact A. HOCK MSR u. ELECTRONIC SERVICE GMBH. IOM's are available in English, German, French and various other languages.

A. Hock MSR- u. Electronic Service GmbH

Dr.-Konrad-Wiegand-Strasse 13
D-63939 Wörth am Main

Valve Division

Tel.: +49 (0) 9372 94 756 -12 Fax -22
info@ahock.com
www.ahock.com

Distributor:



INDUSTRIAL VALVES

www.viragovalves.nl